

Preliminary

TOSHIBA Bi-CMOS IC Silicon Monolithic

TB6582FG

PWM Type, Sine-Wave Current, and Sensorless 3-Phase Full-Wave Brushless Motor Controller

The TB6582FG is designed for controlling the three-phase brushless DC fan motor.

Features

- Sine-wave PWM control
- Built-in triangular-wave generator
(carrier cycle = $f_{osc}/252$ (Hz))
- Built-in dead time function (1.8 μ s)
- Built-in regulator ($V_{refout} = 5$ V (typ.), 5 mA (max))
- Operating supply voltage range: $V_{CC} = 6.5$ to 16.5 V



Weight: 0.45 g (typ.)

The TB6582FG is RoHS-compliant.

About solderability, following conditions were confirmed

- Solderability
 - (1) Use of Sn-37Pb solder Bath
 - solder bath temperature = 230°C
 - dipping time = 5 seconds
 - the number of times = once
 - use of R-type flux
 - (2) Use of Sn-3.0Ag-0.5Cu solder Bath
 - solder bath temperature = 245°C
 - dipping time = 5 seconds
 - the number of times = once
 - use of R-type flux

Block Diagram

Preliminary

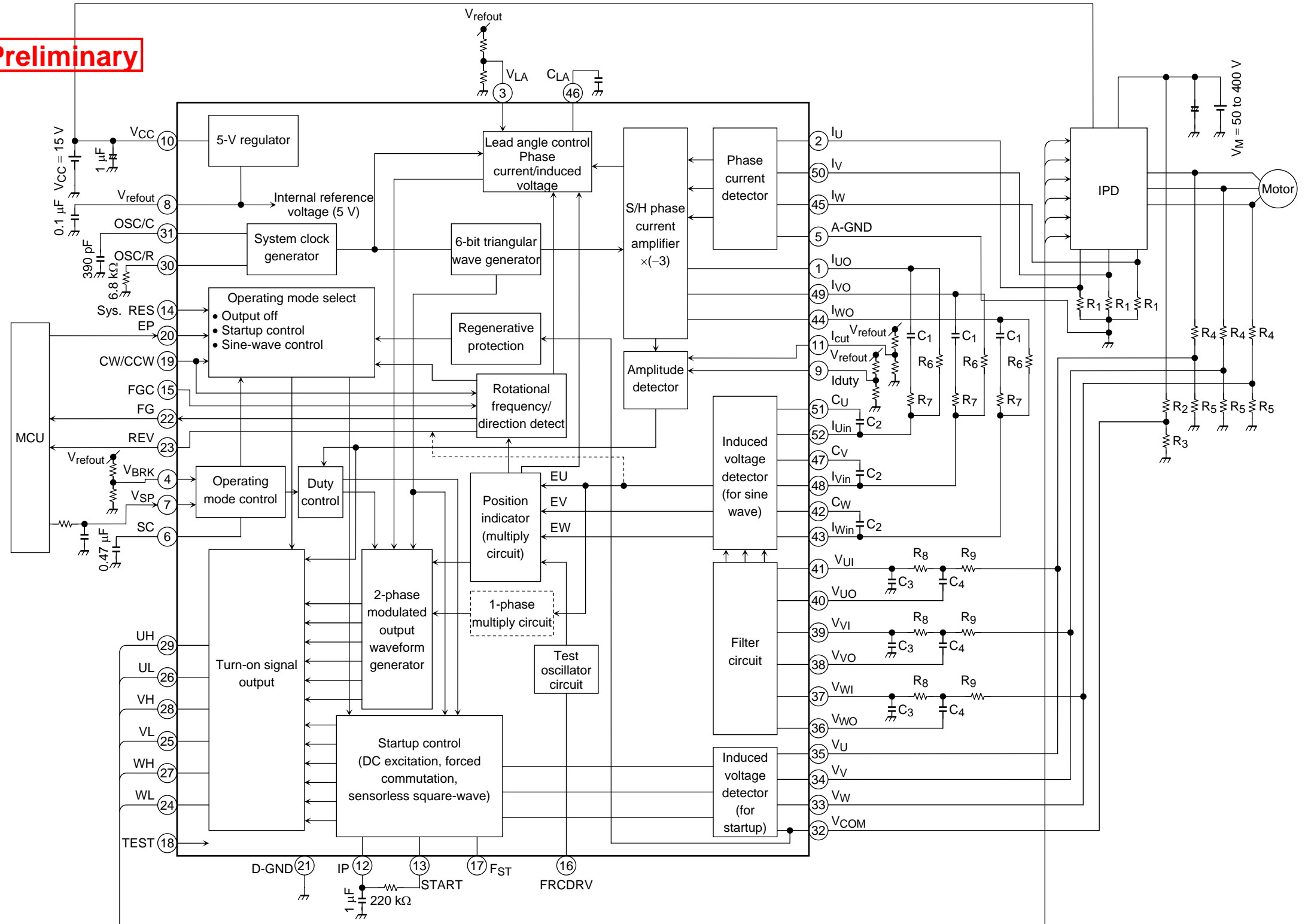

External Parts

Preliminary

Symbol	Function	Recommended Value	Remarks
OSC/C	Reference clock generation (5 MHz)	390 pF	(Note 1)
OSC/R		6.8 k Ω	
C _{SC}	DC excitation setting	3.3 μ F (0.47 to 4.7 μ F)	(Note 2)
R _{ST}		220 k Ω	
C _{IP}		4.7 μ F	
C _{REF}	V _{refout} oscillation prevention	(0.1 μ F)	(Note 3)
C _{VCC}	V _{CC} power supply stabilization	25 V/1 μ F	
R ₁	Phase current detection	0.33 Ω	(Note 4)
R ₂	Motor reference detection	201 k Ω	(Note 5)
R ₃		1 k Ω	
R ₄	Induced voltage detection	200 k Ω	(Note 6)
R ₅		2 k Ω	
R ₆	Motor constant setting	360 k Ω	(Note 7)
R ₇		11 k Ω	
C ₁		0.012 μ F	
C ₂		0.15 μ F	
R ₈	Two-stage low-pass filter	91 k Ω	(Note 8)
R ₉		91 k Ω	
C ₃		0.015 pF	
C ₄		0.0039 μ F	
C _{LA}	Lead angle adjustment	(0.022 μ F)	(Note 9)

- Note 1: These values determine the internal IC reference clock. Recommended values are required to be used for external capacitor and resistor in setting the carrier frequency at 20 KHz.
- Note 2: These are used to determine the DC excitation time and duty cycle at startup. Since those required time and duty cycle vary depending on the motor type, appropriate values must be determined through experiments. Since the motor is driven by a minimum current, these must be connected as close as possible to the IC lead.
- Note 3: These capacitors are used for power supply stabilization. Appropriate values must be determined depending on usage environment. These capacitors must also be connected as close as possible to the IC lead to enhance noise rejection.
- Note 4: The voltage generated at the phase current detection resistor R₁ must be below 0.5 V.
- Note 5: R₂ and R₃ should be adjusted so that the voltages generated at those resistors become half the voltages generated at the induced voltage detection resistors, R₄ and R₅, respectively. Since these voltages are also used for V_M-power supply monitoring, ensure that V_{CC} does not exceed the operating power-supply voltage range. For a detailed functional description, refer to the functional description in Section 16, *V_{CC}-Power Supply Monitoring*.
- Note 6: These resistors are used for the induced voltage detection in square-wave mode. Also, these resistors are used for the detection of the voltage applied to the motor in sine-wave mode. R₄ and R₅ should be adjusted so that the voltage applied to the TB6582FG becomes 4.5 V or lower.
- Note 7: The time constant varies depending on the inductance and resistance of each motor. Thus, attach the motor to the TB6582 and adjust the time constant experimentally. For more details, refer to the functional description in Section 7, *Induced Voltage Detection*.
- Note 8: The PWM signals generated from the output pins must be low-pass filtered to obtain linear voltages.
- Note 9: This capacitor is used to specify the lead angle in sine-wave mode. For the automatic lead-angle correction, the appropriate C_{LA} should be used so that the U-phase current is delayed by the amount of time obtained based on the calculated induced voltage. For more details, refer to the functional description in Section 8, *Lead Angle Correction*.

Preliminary

Pin Description

Pin No.	Symbol	I/O	Description
10	V _{CC}	—	Power supply voltage pin V _{CC} = 6.5 V to 16.5 V
8	V _{refout}	O	Internal reference voltage pin 5 V (typ.)/5 mA (max) Connected to a capacitor of 0.1 μF for power supply stabilization
31	OSC/C	—	Reference clock setting pin Connected to a capacitor
30	OSC/R	—	Reference clock setting pin Connected to a resistor
14	Sys. RES	I	(Test pin) Reset signal input for all the logic (This pin has a pull-down resistor of 100 kΩ typ.) High : Motor operation Low : Reset *: This pin is held at High under actual operation.
20	EP	I	Driving output control pin. Activated to reset when any faults is detected. (This pin has a pull-down resistor of 100 kΩ (typ.)) High: Motor operation Low: Motor stop (Free run) *) Rotation speed signal (FG) pin is always active regardless of the EP input
19	CW/CCW	I	Forward/Reverse rotation select pin (This pin has a pull-down resistor of 100 kΩ typ.) High : Reverse Low : Forward
15	FGC	I	FG output select pin (This pin has a pull-down resistor of 100 kΩ typ.) High : 1 ppr Low : 3 ppr (Square-wave mode when FGC = 2.5 V (typ.), FG = 3 ppr)
22	FG	O	Rotation speed detect signal output Selectable between 3 ppr and 1 ppr with the FGC pin.
23	REV	O	Reverse rotation output pin (Generates the calculated U-phase induced voltage when FGC = 2.5 V typ.)
4	V _{BRK}	I	Torque command for the reverse rotation brake control V _{BRK} input voltage range: 1.5 V < V _{BRK} ≤ 2.5 V Duty cycle = 52% when V _{BRK} = 1.5 V
7	V _{SP}	I	Motor speed control input (This pin has a pull-down resistor of 200 kΩ typ.) 0 ≤ V _{SP} ≤ < 2.1 V (typ.): Output Off (all phases: Low) 2.1 V (typ.) ≤ V _{SP} ≤ 5.4 V (typ.): Set the PWM duty cycle according to the speed control input.
6	SC	I	Connection pin for a capacitor to set a ramp-up period during duty-cycle operation in DC excitation mode
29	UH	O	Upper arm driving signal output ±2 mA _{max}
26	UL	O	Lower arm driving signal output ±2 mA _{max}
28	VH	O	Upper arm driving signal output ±2 mA _{max}
25	VL	O	Lower arm driving signal output ±2 mA _{max}
27	WH	O	Upper arm driving signal output ±2 mA _{max}
24	WL	O	Lower arm driving signal output ±2 mA _{max}
18	TEST	I	Test pin for the shipping inspection. (This pin has a pull-down resistor of 100 kΩ typ.) *: This pin is left Open or held at Low during actual operation of the motor.
21	D-GND	—	Ground pin for digital circuits
12	IP	I	DC excitation time setting pin When V _{SP} ≥ 2.1 V (typ.), the START pin goes low to start DC excitation.
13	START	O	When the IP pin voltage reaches 0.5 V, operating mode is switched from DC excitation to forced commutation.
17	F _{ST}	I	Forced commutation frequency select pin (This pin has a pull-down resistor of 100 kΩ typ.) High : Forced commutation frequency f _{ST} = f _{osc} /(6 × 2 ¹⁷) Middle : Forced commutation frequency f _{ST} = f _{osc} /(6 × 2 ¹⁸) Low : Forced commutation frequency f _{ST} = f _{osc} /(6 × 2 ¹⁹)
16	FRCDRV	I	(Test pin) Motor constant setting pin for induced voltage detection circuit (This pin has pull-up/down resistors of 100 kΩ typ. *2) High : Low-speed oscillation (0.5 Hz) Middle or OPEN : Motor operation Low : High-speed oscillation (30 Hz) *: The CW/CCW pin must be set Low while changing the setting of this pin. *: This pin is left Open during actual operation of the motor.
32	V _{COM}	I	Voltage supply for the V _M voltage level shift, The voltage applied to this pin should be half the input voltage at the induced voltage detection inputs (V _U , V _V and V _W).

Pin No.	Symbol	I/O	Description	Preliminary
33	V _W	I	Induced voltage detection input	
34	V _V	I	Induced voltage detection input	
35	V _U	I	Induced voltage detection input	
36	V _{WO}	O	Induced voltage detection filter pin	
37	V _{WI}	I	Induced voltage detection filter pin	
38	V _{VO}	O	Induced voltage detection filter pin	
39	V _{VI}	I	Induced voltage detection filter pin	
40	V _{UO}	O	Induced voltage detection filter pin	
41	V _{UI}	I	Induced voltage detection filter pin	
43	I _{Win}	I	Detected phase current signal input	
42	C _W	—	Phase current detection pin (A capacitor is connected to this pin.)	
48	I _{Vin}	I	Detected phase current signal input	
47	C _V	—	Phase current detection pin (A capacitor is connected to this pin.)	
52	I _{Uin}	I	Detected phase current signal input	
51	C _U	—	Phase current detection pin (A capacitor is connected to this pin.)	
9	I _{duty}	I	Current limiting signal input pin (Limit the phase current so as not to exceed the set current value.)	
11	I _{cut}	I	Current-off signal input (Set the output off)	
44	I _{WO}	O	Detected phase current signal output	
49	I _{VO}	O	Detected phase current signal output	
1	I _{UO}	O	Detected phase current signal output	
5	A-GND	—	Ground pin for analog circuits. This pin should be connected as close as possible to the grounded side of the shunt resistor R ₁ .	
45	I _W	I	Voltage signal input converted from a shunt current signal	
50	I _V	I	Voltage signal input converted from a shunt current signal	
2	I _U	I	Voltage signal input converted from a shunt current signal	
46	C _{LA}	—	Lead angle setting pin (A delay capacitor is connected to this pin.)	
3	V _{LA}	I	Reference lead-angle correction pin (Electrical angle of 112.5° is programmable for 16 steps (using 4 bits) at the 112.5/16 resolution.) (This pin has a pull-down resistor of 200 kΩ typ.)	

Pin Assignment

Preliminary

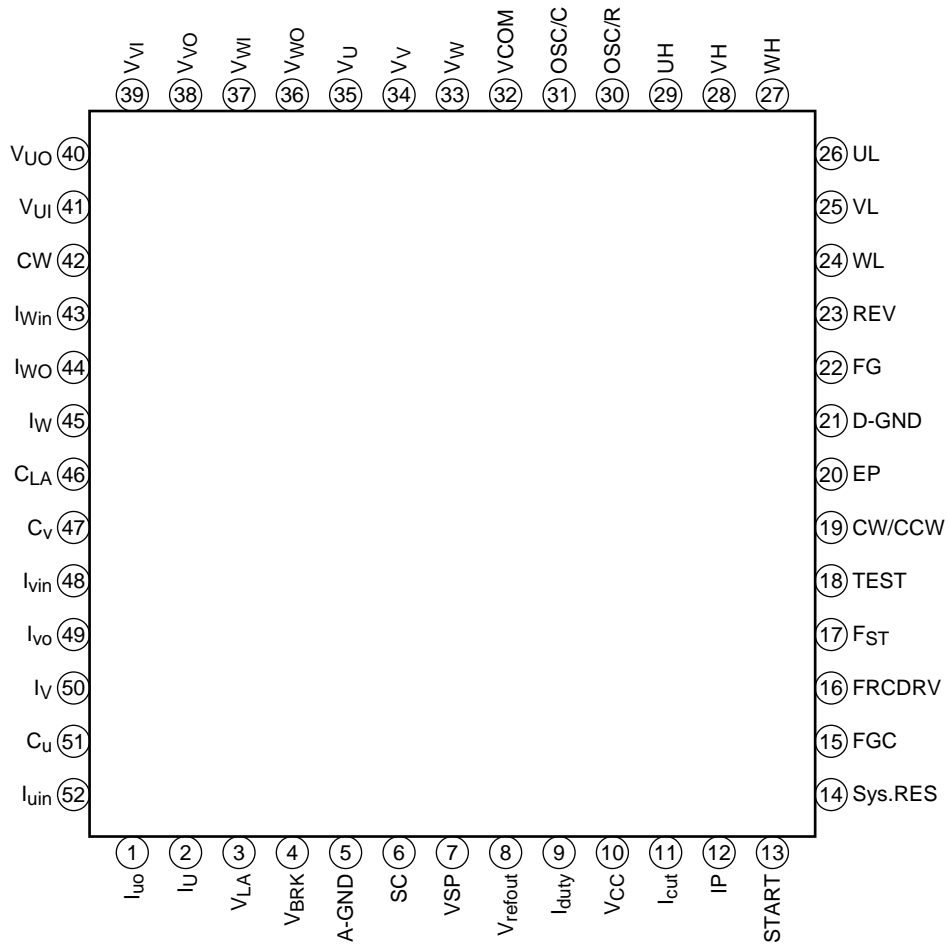

Absolute Maximum Ratings (Ta = 25°C)

Preliminary

Characteristics	Symbol	Rating	Unit
Power supply voltage	V _{CC}	18	V
Input voltage	V _{IN}	-0.3 to V _{refout} + 0.3 (Note 1)	V
	V _{SP}	-0.3 to 11.5 (Note 2)	
	V _{COM}	V _{refout}	
Turn-on signal output current	I _{OUT}	±2	mA
Power dissipation	P _D	0.9 (Note 3)	W
		1.45 (Note 4)	
Operating temperature	T _{opr}	-30 to 115	°C
Storage temperature	T _{stg}	-55 to 150	°C

Note 1: EP, CW/CCW, FGC, Sys.RES, FRCDRV, Fst, V_{LA}, V_{BRK}, Iduty and Icut

Note 2: V_{CC} ≥ V_{SP}

Note 3: For IC only

Note 4: Measured when mounted on the board
(Glass epoxy: 75 mm × 114 mm × 1.6 mm, Copper foil: 20%)

Operating Condition (Ta = 25°C)

Characteristics	Symbol	Min	Typ.	Max	Unit
V _{CC} power supply voltage	V _{CC}	6.5	15	16.5	V
Oscillation frequency range	F _{OSC}	4	5	6	MHz

Preliminary

Electrical Characteristics (Ta = 25°C, VCC = 15 V)

Characteristics	Symbol	Test condition	Min	Typ.	Max	Unit	
Power supply current	I _{CC}	V _{refout} = OPEN	5	10	16	mA	
Input current	I _{in} (1)	V _{in} = 0 V V _{sp} , EP, CW/CCW, FGC, V _{LA}	—	0	—	μA	
	I _{in} (2)	V _{in} = 5 V V _{sp} , V _{LA}	—	25	50		
	I _{in} (3)	V _{in} = 0 V FRCDRV	-100	-50	—		
	I _{in} (4)	V _{in} = 5 V EP, CW/CCW, FGC, FRCDRV, Fst	—	50	100		
	I _{in} (5)	V _{in} = 0 V Sys.RES	-6	-3	—		
	I _{in} (6)	V _{in} = 5 V Sys.RES	—	0	—		
Input voltage	V _{in} (1)	H	EP, CW/CCW, FGC, FRCDRV	V _{refout} - 1	—	V _{refout}	V
		L		—	—	0.8	
	V _{in} (2)	H	FST, FGC, FRCDRV	4.0	—	V _{refout}	V
		M		2.0	—	3.0	
	V _{in} (3)	L	Sys.RES	0	—	1.0	V
		H		V _{refout} - 1	—	V _{refout}	
	V _{sp}	L	Modulation wave: 90% typ.	5.1	5.4	5.7	V
		H		1.8	2.1	2.4	
Output duty cycle (max)	T _{on} (max)	OSC/C = 390 pF, OSC/R = 6.8 kΩ V _{sp} = 5.7 V	87	90	93	%	
Input delay	T _{DC}	I _{cut} when in sine-wave mode OSC = 5 MHz	—	(2.0)	—	μs	
Charge current for SC	I _{SC}	DC excitation mode	0.6	1.2	1.8	μA	
Threshold voltage for mode switching from DC excitation mode to forced commutation mode	V _{IP}	DC excitation → forced commutation	0.3	0.5	0.7	V	
	V _H (1)	Hysteresis	—	±12	—	mV	
Output voltage	V _{OUT} (H)-1	I _{OUT} = 2 mA UH, UL, VH, VL, WH, WL	V _{refout} - 0.5	V _{refout} - 0.2	—	V	
	V _{OUT} (L)-1	I _{OUT} = -2 mA UH, UL, VH, VL, WH, WL	—	0.2	0.5		
	V _{REV} (H)	I _{OUT} = 1 mA REV	V _{refout} - 1.0	V _{refout} - 0.2	—		
	V _{REV} (L)	I _{OUT} = -1 mA REV	—	0.2	1.0		
	V _{FG} (H)	I _{OUT} = 1 mA FG	V _{refout} - 1.0	V _{refout} - 0.2	—		
	V _{FG} (L)	I _{OUT} = -1 mA FG	—	0.2	1.0		
	V _{refout}	I _{OUT} = 5 mA V _{refout}	4.5	5.0	5.5		
Output leakage current	I _L (H)	V _{OUT} = 0 V UH, UL, VH, VL, WH, WL	—	0	10	μA	
	I _L (L)	V _{OUT} = 5 V UH, UL, VH, VL, WH, WL	-10	0	—		
Output off time by high/low-side transistor	T _{OFF}	OSC = 5 MHz, I _{OUT} = ± 2 mA	1.5	1.8	2.1	μs	
PWM frequency (Carrier frequency)	F _C	OSC/C = 390 pF, OSC/R = 6.8 kΩ	18	20	22	kHz	
Reverse rotation brake	V _{BRK}	V _{BRK} = 1.5 V, OSC = 5 MHz, reverse rotation start	—	52	—	%	
Motor power supply monitor	V _{COM} (H)	Drive output off	2.1	2.2	2.3	V	
	V _{COM} (L)	Drive output restart	1.75	1.85	1.95		
	V _H (2)	Input hysteresis width	—	0.35	—		
V _{CC} monitor	V _{CC} (H)	Output start point	4.2	4.5	4.8	V	
	V _{CC} (L)	Output stop point	3.7	4.0	4.3		
	V _H (3)	Input hysteresis width	—	0.5	—		

Functional Description

Preliminary

1. Basic Operation

The TB6582FG is a sensorless 3-phase hall motor controller driven by the sine wave. It provides a sensorless square-wave drive with zero-cross detection of the induced voltage, without using position sensors, such as a Hall-effect element. It also achieves a sensorless sine-wave drive by calculating the induced voltage waveform using the induced voltage equation.

At startup, the motor operates in sensorless square-wave mode. The operation mode switches to sensorless sine-wave mode when the rotation speed reaches 90 rpm in the case of an 8-pole motor.

Basic Operation Flow

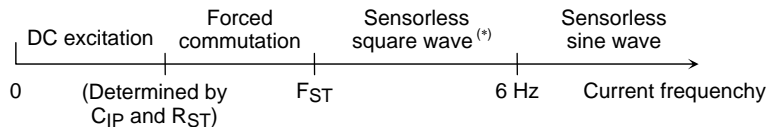

*: A refresh operation is not performed.

<Rotation Speed for Drive-Signal Switching>

Rotation speed is converted from the phase-current frequency Tu. When Tu reaches 6 Hz, the drive signal is switched between square wave and sine wave.

Rotation speed: $R \text{ (rpm)} = 60 \times Tu \times (2/N)$ $Tu = 6 \text{ Hz}$, N = Number of motor poles

Example) When using a 8-pole motor

$R = 60 \times 6 \times 2/8 = 90 \text{ (rpm)}$

Thus,

- Sensorless square-wave drive: From start to 90 rpm
- Sensorless sine-wave drive: 90 rpm ~

2. Drive Control with Operation Instruction Input (V_{SP})

Control the commutation output with V_{SP} input voltage.

- (1) Voltage instruction input: $0 \text{ V} \leq V_{SP} < 2.1 \text{ V}$
Disables (Low) the commutation output
- (2) Voltage instruction input: $2.1 \text{ V} \leq V_{SP} \leq 8.5 \text{ V}$
Controls the motor drive.

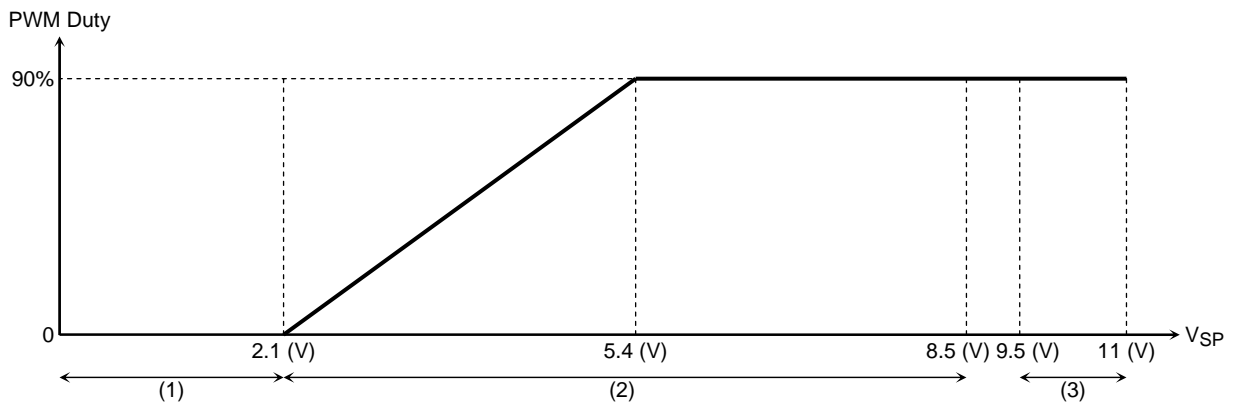

- (3) Voltage instruction input: $9.5 \text{ V} \leq V_{SP} \leq 11 \text{ V}$ (Test mode)
Automatic lead-angle correction feature is disabled.
A mode switching occurs when $V_{SP} = 9.0 \text{ V}$ (typ.).

Instructions used in each operation mode are listed below.

Preliminary

Operation Mode	Instructions	
Reverse rotation brake	V_{BRK}	
DC excitation	DC excitation for startup	DC excitation for reverse rotation
	C_{SC} charge voltage	V_{SP} input voltage
Forced commutation	V_{SP} input voltage	
Sensorless square-wave	V_{SP} input voltage	
Sensorless sine-wave	V_{SP} input voltage	

3. Startup Control When the Motor is Stopped (Motor frequency ≤ 4 Hz)

The TB6582FG starts the motor operation with the operation instructions from VSP input and the operating-mode-select circuit.

At startup, since the motor is not rotating, the motor is started applying forced commutation signal, producing the induced voltage. When the induced-voltage frequency exceeds the forced commutation frequency specified with the status of the FST pin, the motor starts to be driven in sensorless square-wave mode. And when the phase current frequency reaches 6 Hz or higher, and the operating mode is switched to sensorless sine-wave mode.

At startup, the rotor is aligned to a known position and the rotation is started in forced commutation mode. The mode switching timing from DC excitation mode to forced commutation mode can be determined by an external capacitor.

Since the durations of DC excitation and forced commutation vary depending on the motor type and motor loading, experiments are required for proper adjustment.

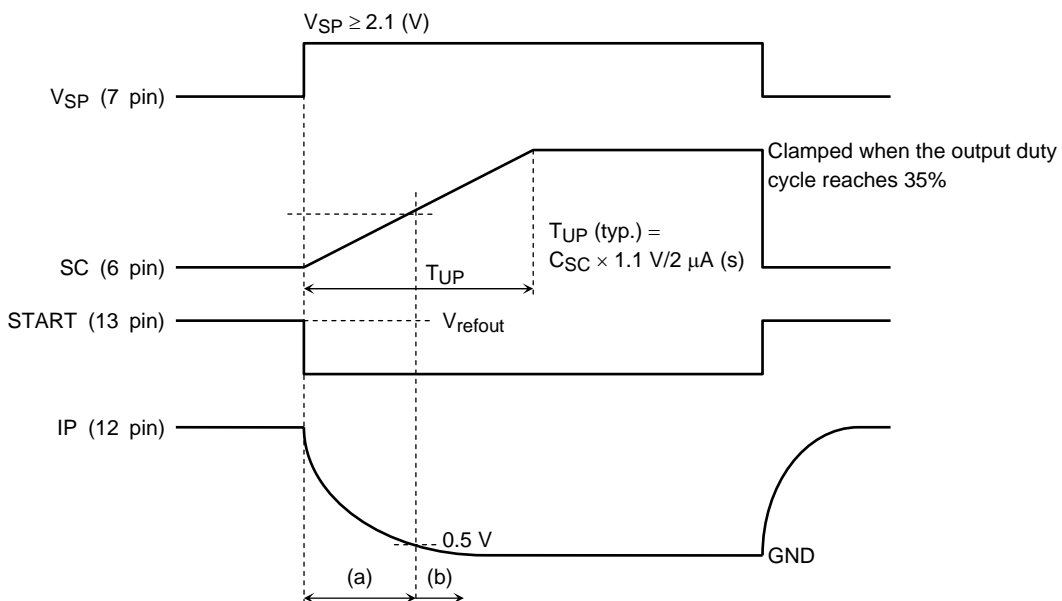
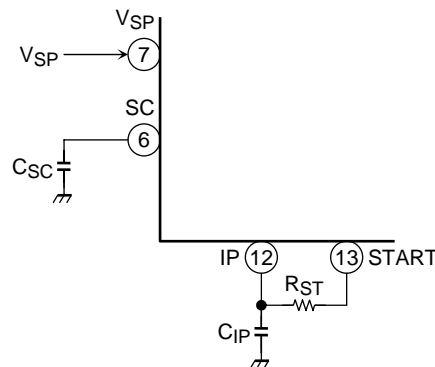

(a) DC excitation time

Duty cycle is determined by the gradient of SC terminal voltage, which depends on the charging of a capacitor.

This voltage is clamped when the output duty cycle reaches about 35% for the de-excitation and over-current protection.

When CW = U-phase → V-phase

When CCW = U-phase → W-phase

Preliminary

$$T_a (\text{typ.}) = 2.3 \times C_{IP} \times R_{ST} (\text{s})$$

(b) Forced commutation time

The forced commutation is started when the IP pin voltage falls below to 0.5 V or lower.

The output duty cycle of forced commutation is determined by V_{SP} input voltage.

F_{ST} = High : Forced commutation frequency $f_{ST} = f_{osc}/(6 \times 2^{17})$

F_{ST} = Middle : Forced commutation frequency $f_{ST} = f_{osc}/(6 \times 2^{18})$

F_{ST} = Low : Forced commutation frequency $f_{ST} = f_{osc}/(6 \times 2^{19})$

Example) When $f_{OSC} = 5 \text{ MHz}$,

F_{ST} = High : $f_{ST} \approx 6.4 \text{ (Hz)}$

F_{ST} = Middle : $f_{ST} \approx 3.2 \text{ (Hz)}$

F_{ST} = Low or Open : $f_{ST} \approx 1.6 \text{ (Hz)}$

The rotor is aligned to a certain position specified in DC excitation mode for the period of (a), during which the IP pin voltage decreases from V_{refout} to 0.5 V. The time constant for the period is determined by C_{IP} and R_{ST}. After that, operation mode is switched to forced commutation mode (b) as shown above. The duty cycle for DC excitation mode is determined according to the SC pin voltage. And after the IP pin voltage falls to 0.5 V or lower, the duty cycle is determined according to the V_{SP} pin voltage. When the rotational frequency exceeds the forced commutation frequency specified with the status of the F_{ST} pin, the operation mode is switched to the sensorless square-wave mode.

4. Controls the commutation output with the input signal status and motor operation status.

Preliminary

Input information to the IC						IC output			Motor status
EP	V _{SP}	CW/CCW	VM (V _{COM})	Initial state of the motor		Control	Output	Rotation detection (FG, REV)	
				Rotation speed	Rotation direction				
Low	—	—	—	—	—	All drive outputs: Low	OFF	ON	Free run
High	0 to 2.1 V	—	Within the setting range	—	—	All drive outputs: Low	OFF	ON	Free run
	2.1 to 5.4 V	CW		Stop	—	DC excitation for startup → forced commutation → sensorless square wave → sensorless sine wave	Start rotation in CW direction	ON	Drive
				Stop	—		Start rotation in CCW direction	ON	Drive
		CCW		Rotate	CW	Sensorless square wave → sensorless sine wave	Forward rotation in CW direction	ON	Drive
				Rotate	CCW	Reverse rotation brake → DC excitation for reverse rotation → forced commutation → sensorless square wave → sensorless sine wave	Reverse rotation in CW direction	ON	Drive
		CW		Rotate	CCW	Sensorless square wave → sensorless sine wave	Forward rotation in CCW direction	ON	Drive
				Rotate	CW	Reverse rotation brake → DC excitation for reverse rotation → forced commutation → sensorless square wave → sensorless sine wave	Reverse rotation in CCW direction	ON	Drive
	0 to 5.4 V	—		Out of the setting range	—	—	All drive outputs: Low	OFF	ON

Note 1: Since the Sys.RES input is a higher priority input, all the logic are turned off when the Sys.RES goes Low, which puts the motor in free run mode. Thus, the above table shows the motor status when the Sys.RES signal is High.

Note 2: —: Don't care.

5. Phase Current Detection Circuit

The phase current detection at each phase of the coil is performed using the shunt resistor (R_f) connected between the low-side output driver (IGBT or FET) and GND. The induced voltage at the shunt resistor is amplified 3 times to be used as the internal signal. Since the current-voltage converted value is processed based on 2.5 V, the maximum amplitude of shunt voltage must not exceed 0.5 V.

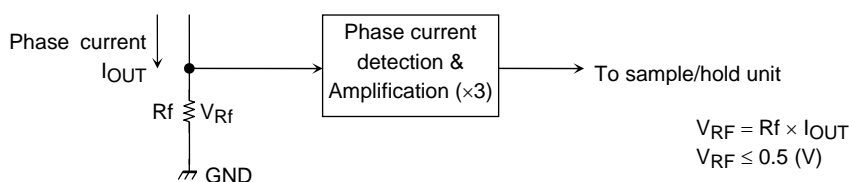

6. Sample and Hold of the Phase Current

The pseudo-sine waveform is generated from the PWM waveform by sampling and holding the voltage value that is converted from the detected phase-current value as described in section 5. The sample-and-hold timing is synchronized with the carrier frequency.

Preliminary

Detection Image

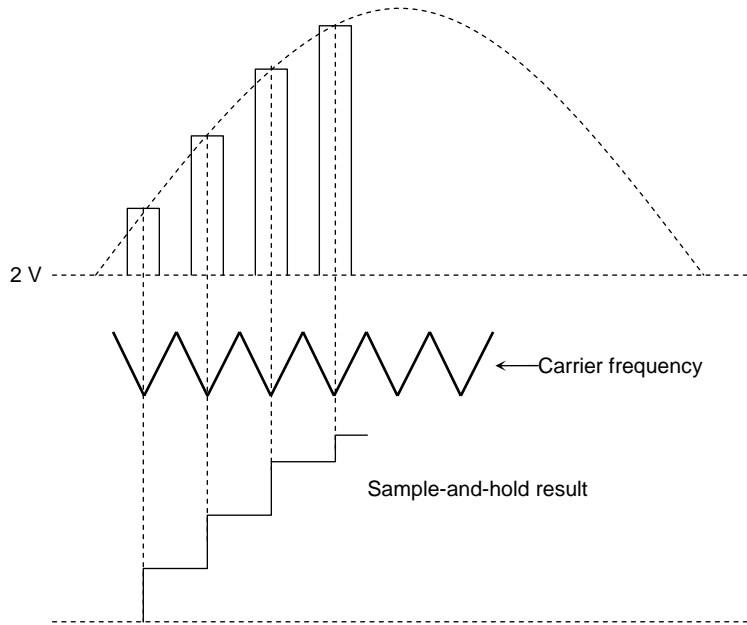

Waveform Simulation for the Operation Check (shunt current/sample and hold, CW/CCW = Low)

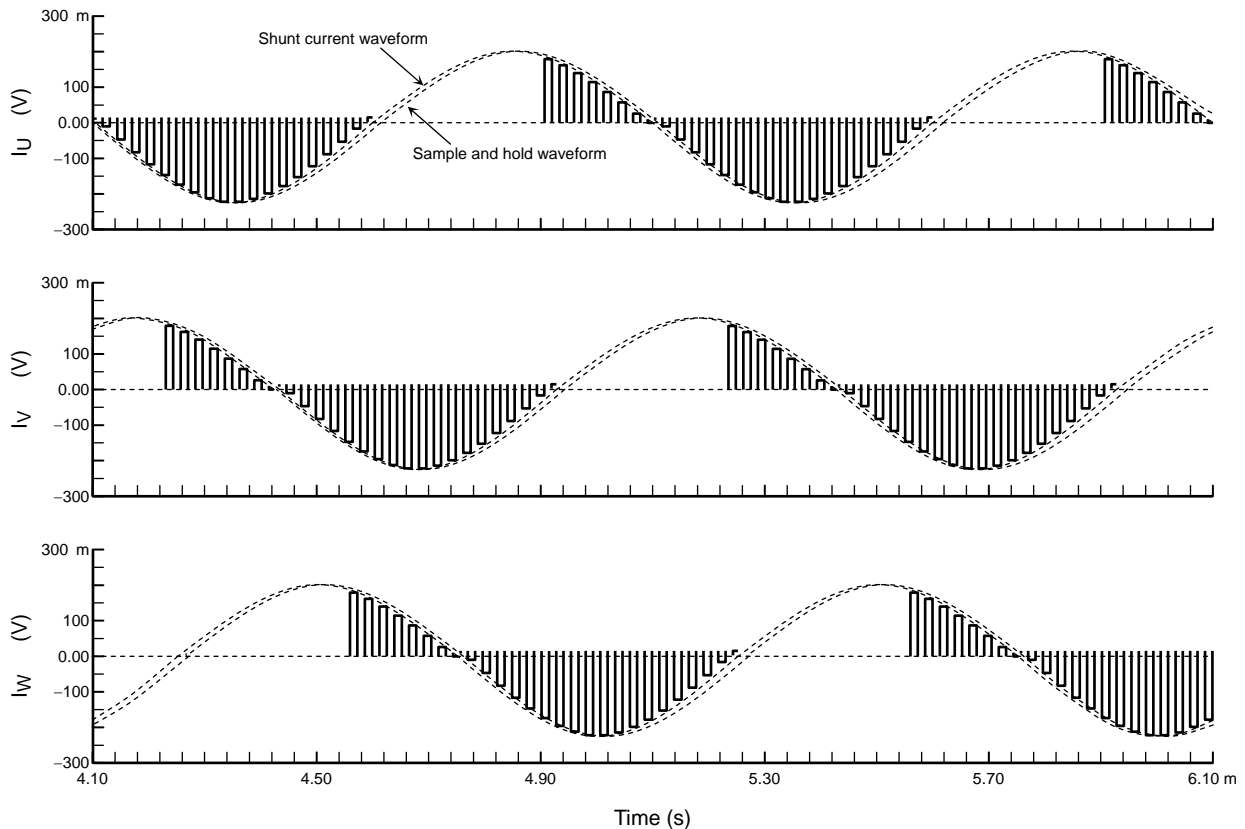

7. Induced Voltage Detection

(Sine-wave generation)

The induced voltages of each phase are detected by applying an analog calculation to the current signal generated in section 6 and the voltage signal detected at the motor.

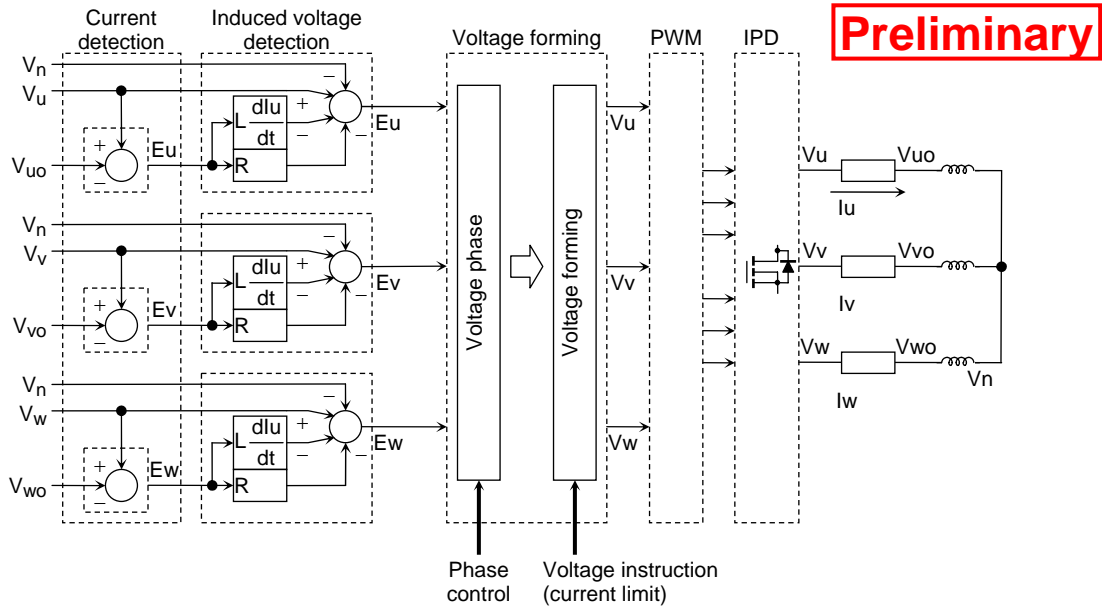

Phase voltage equation

$$E_u = (V_u - V_n) - L \times \frac{dI_u}{dt} - R \times I_u$$

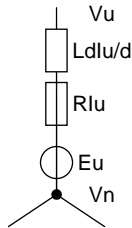

Motor equivalent circuit

<Determining the time constant of a motor >

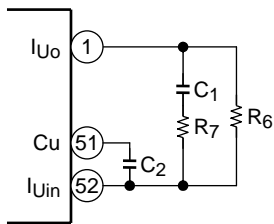

To complete the phase voltage equation, values of external C₁, R₆ and R₇ are determined experimentally. It can be achieved by setting the FRCDRV pin High (5 V) or Low (0 V). The recommended capacitor value for C₂ is the range of about 0.01 μF to 0.047 μF. However, it should be adjusted according to noise conditions.

- When FRCDRV goes Low, the current frequency signal of 0.5 Hz is generated at the drive output. At this time, a resistor value of R₆ must be determined so as to keep the Cu voltage constant at 2.5 V.
- When FRCDRV goes High, the current frequency signal of 30 Hz is generated at the drive output. At this time, values of a capacitor C₁ and a resistor R₇ must be determined so as to keep the Cu voltage constant at 2.5 V.

Note: Under normal operation, the FRCDRV pin voltage must be 2.5 V, or the pin must be left open.

(Square-wave generation)

A square wave for startup-operation control performs a control function by detecting the 60° commutation time using the induced voltage that is generated while the motor is not commutating. The square-wave drive operates until the phase-current frequency reaches 6 Hz (90 rpm for an 8-pole motor).

8. Lead Angle Correction

The phase-current delay is corrected by comparing the phase current from the shunt resistor circuit (U-phase) and the induced voltage detected at the induced voltage detection circuit (U-phase).

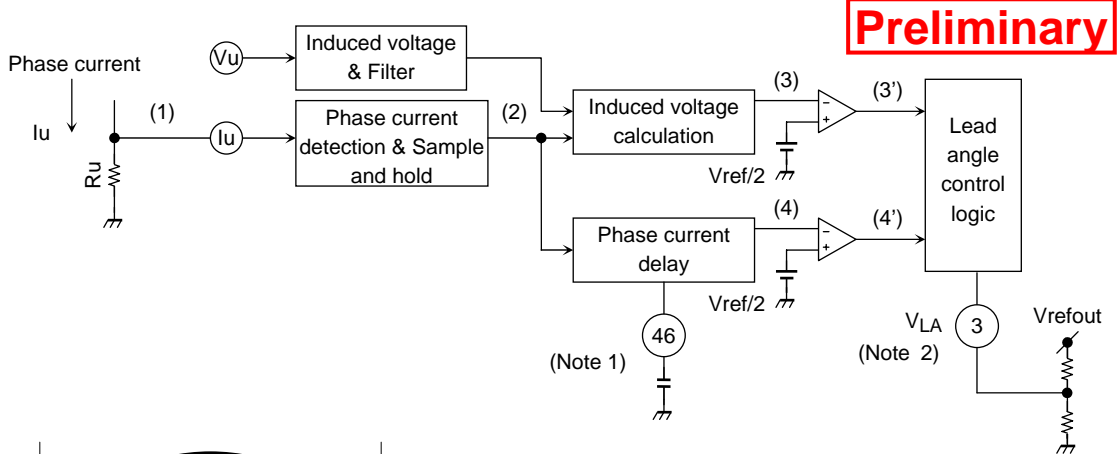

Preliminary

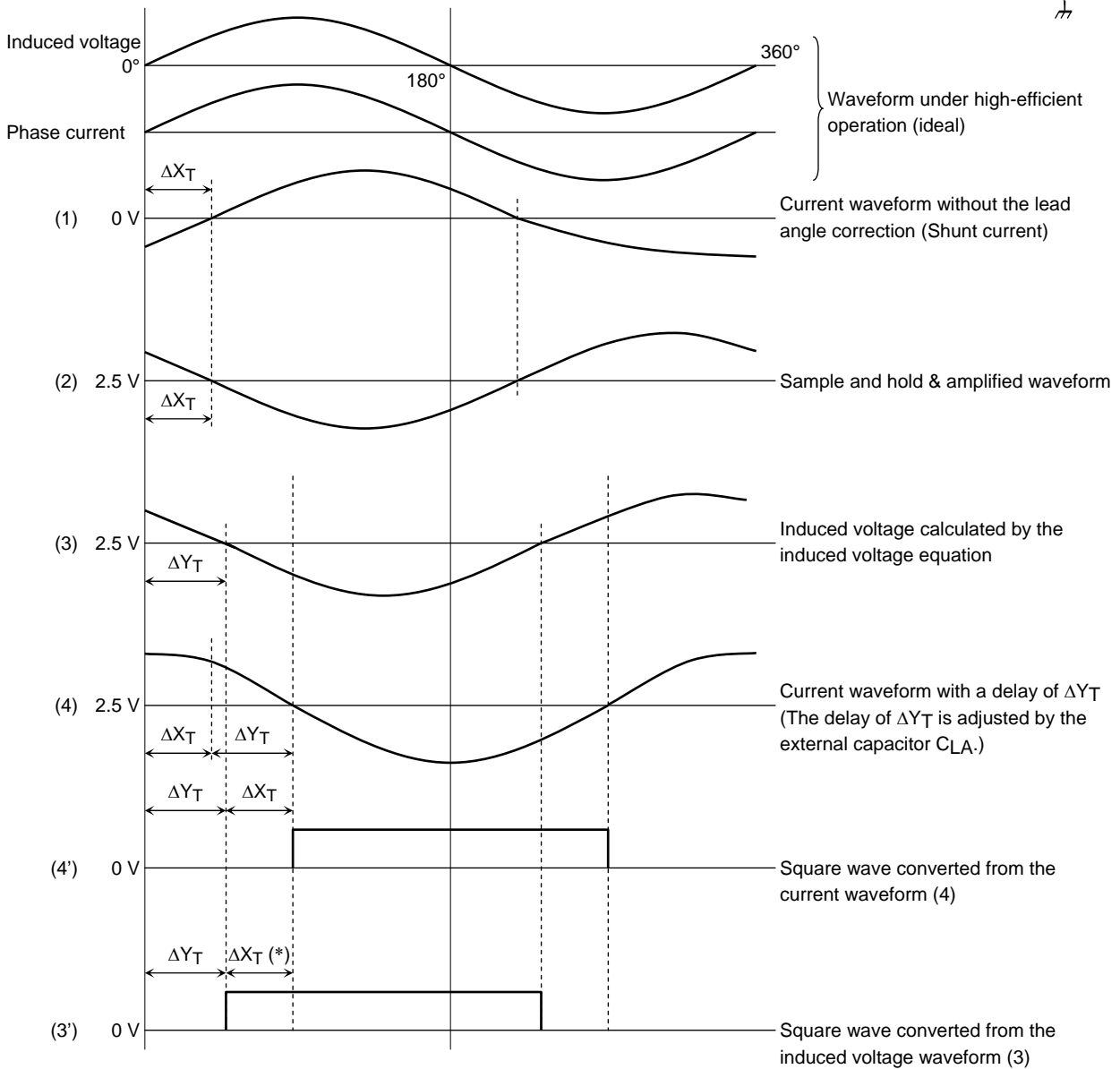

*: The lead angle correction logic is applied to correct the misalignment of ΔX_T .

Note 1: Determining the capacitor value of C_{LA}

The difference between the zero-cross point of the induced voltage generated at the U-phase output and the one of the induced voltage calculated by the TB6582FG should be measured by experiment while the motor is operating in square-wave drive (120° commutation) mode. The C_{LA} capacitor value should be specified corresponding to the measurement result.

Preliminary

< **Determination Procedure** >

- (1) When the motor is driven by the square wave (120° commutation), an input voltage of 2.5 V must be applied to the FGC pin. When $FGC = 2.5\text{ V}$, the TB6582FG enters into Test mode and the REV pin generates an induced voltage output of phase U calculated internally.
- (2) The motor should be operated with a rotation speed appropriate for the normal usage (, such as 700 rpm) in 120° commutation by applying an appropriate voltage to the VSP pin.
- (3) Measure the difference (ΔY_T) between the zero-cross points of the U-phase output and the REV output.
- (4) The capacitor value of C_{LA} should be determined according to the delay time (ΔY_T).

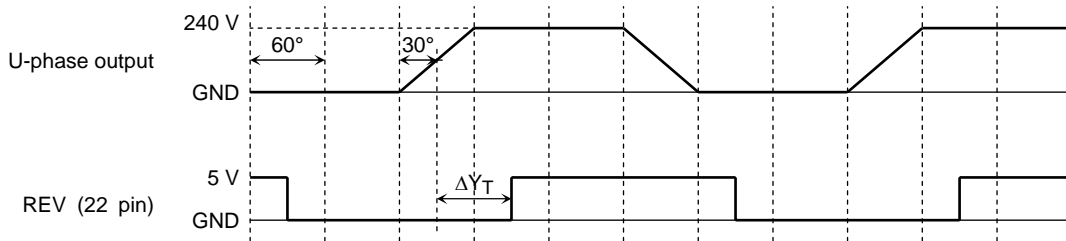

Figure 1

Table 1. C_{LA} Values Corresponding to the Delay Time ΔY_T

ΔY_T	C_{LA}
30°	(103)
60°	(223)
120°	(473)

The external capacitor C_2 considerably affects the factor that causes the delay time in the induced voltage calculation. A capacitor of the same value as C_2 should be connected to the C_{LA} pin while checking the basic operations. Since the appropriate capacitance and resistance of the external components vary depending on the motor type, they must be adjusted experimentally.

When $FGC = 2.5\text{ V}$, the internally-detected induced voltage is generated from the REV pin as a square-wave signal. This signal is delayed by the amount of time specified by C_{LA} .

Note 2: Since drive signals are generated by the calculated induced voltage, the outputs of those signals are enabled with a certain delay time. Though the automatic lead-angle correction is applied, the lead angle can also be adjusted in the early stages. The range of the lead-angle correction is from 0° to 112.5° and the four-bit resolution (16 steps) can be programmed.

Analog input to the VLA pin (0 to 5 V range is resolved to 16 steps)

0 V = 0°

5.0 V = 112.5°

< **Target Operation** >

Resolution	VLA (V)	Lead angle value (°)	Resolution	VLA (V)	Lead angle value (°)
1	0 to 0.312	0	9	2.50 to 2.812	60
2	0.312 to 0.625	7.5	10	2.812 to 3.125	67.5
3	0.625 to 0.937	15	11	3.125 to 3.437	75
4	0.937 to 1.25	22.5	12	3.437 to 3.750	82.5
5	1.250 to 1.562	30	13	3.750 to 4.062	90
6	1.562 to 1.875	37.5	14	4.062 to 4.375	97.5
7	1.875 to 2.187	45	15	4.375 to 4.687	105
8	2.187 to 2.500	52.5	16	4.687 to 5.0	112.5

(Hys. = 0.1 V)

9. 5-V-Internal Regulator

External input voltage at $V_{CC} = 15\text{ V}$ (typ.) is dropped to 5 V so as to be used as the reference voltage for the internal circuits of the IC. The reference voltage is generated at the V_{refout} pin, to which a pull-up resistor can be connected (5 V, 5 mA (max)). A capacitor must also be connected for oscillation protection.

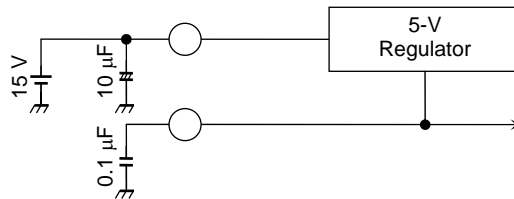

Preliminary

10. Setting Carrier Frequency

Sets triangular-wave frequency (carrier frequency) required to generate the PWM signal at the drive output.

Carrier frequency = $f_{osc}/252$ (Hz) f_{osc} = Reference clock (CR oscillation frequency)

Example) When $f_{osc} = 5\text{ MHz}$, $f_c = 19.8\text{ kHz}$

11. Dead Time Function (high/low-side transistor output off-time)

When the motor is driven by sine-wave PWM, digitally generates the dead time in the IC to prevent a short circuit caused by simultaneously turning on high/low-side external power devices. (When a square-wave is generated in full duty cycle mode, the dead time function is also turned on to prevent a short circuit.)

$T_{OFF} = 9/f_{osc}$

When $f_{osc} = 5\text{ MHz}$, $T_{OFF} = 1.8\ \mu\text{s}$

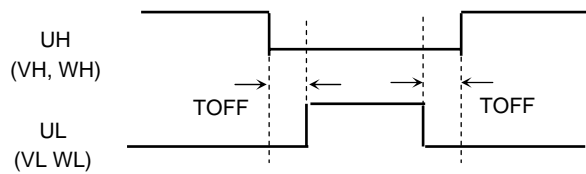

12. Outputting the Reverse Rotation Detection Signal

Detects motor rotation direction.

The detection is performed at every electrical angle of 360° . (The output immediately after reset is High.)

When the REV pin is Low, the 180° commutation drive mode (current frequency = 6 Hz or higher) is turned on.

CW/CCW pin	Actual rotation direction of the motor	REV pin
Low (CW)	CW (forward)	Low
	CCW (reverse)	High
High (CCW)	CW (forward)	High
	CCW (reverse)	Low

13. Reverse Rotation Brake

When the motor is rotating in reverse direction due to conditions like adverse wind, the direction of the motor rotation is corrected to the regular direction (specified with the CW/CCW pin) using the reverse rotation brake. The torque command for the brake control is specified by the VBRK input voltage. The VBRK input voltage range is: $1.5\text{ V} < V_{BRK} < V_{refout}$. However, when VBRK reaches 2.33 V (Duty cycle = 88%). The default setting for the VBRK input voltage should be 1.35 V (Duty cycle = 52%).

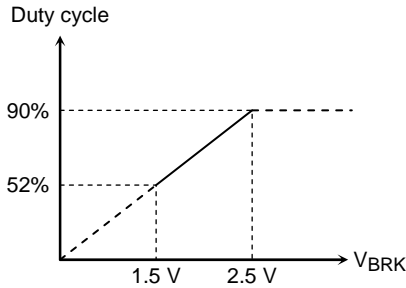

Preliminary

Timing Chart of the Reverse Rotation Brake Operation

If a reverse rotation of the motor is detected, the rotation direction is corrected to the regular direction by rotating the motor in the opposite direction with a 120°-commutation signal.

The operation image of the drive outputs corresponding to detected voltages E_u , E_v and E_w is illustrated below.

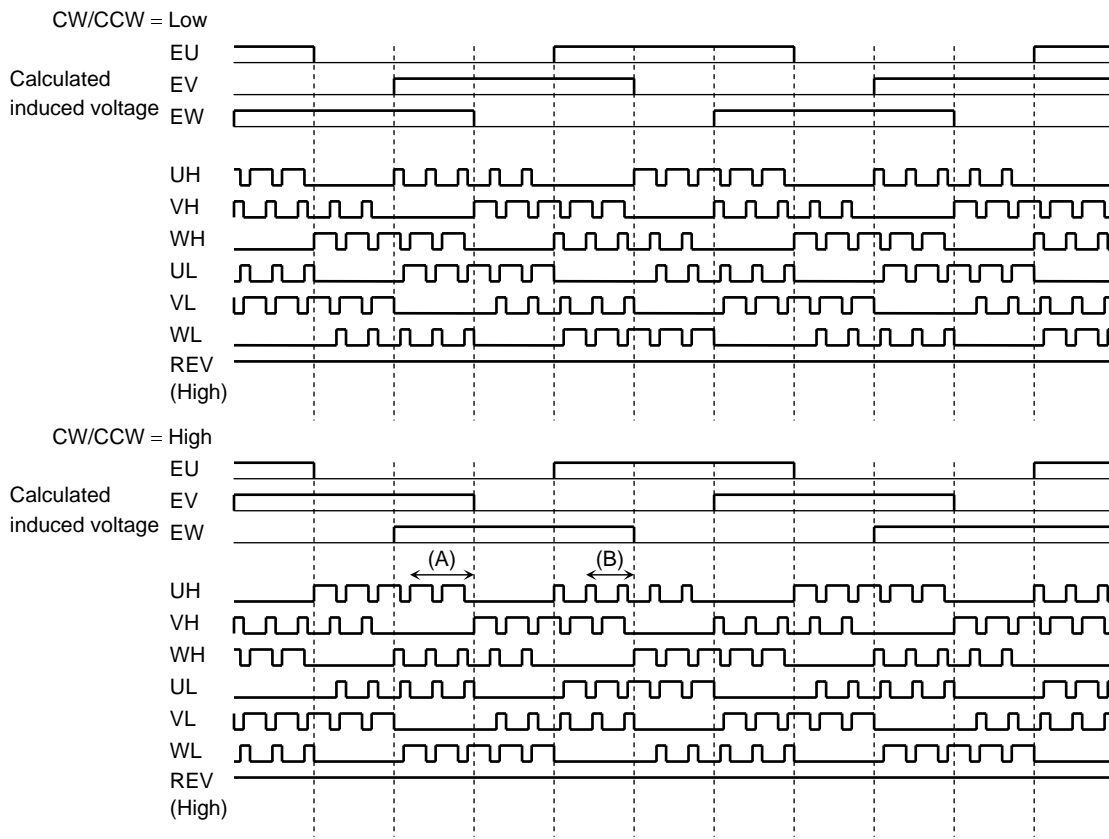

(A) When the output is sourcing current

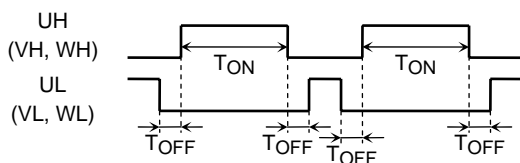

(B) When the output is sinking current

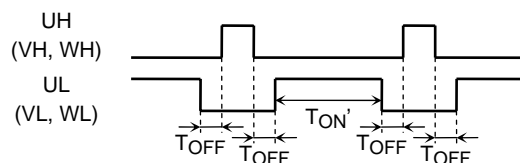

Though T_{ON}' varies according to the V_{BRK} input, $T_{ON} \neq T_{ON}'$ due to the generated dead time T_{OFF} .

14. Limiting the Output Pulse Width

The pulse width of the drive output signal must be less than 0.4 μ s so that the external output driver would not be damaged.

Preliminary

15. Rotation Pulse Output Pin

Generates a rotation pulse based on the induced voltage. The pulse can be selected by the FGC input between 1 pulse/electrical rotation and 3 pulses/electrical rotation. 1 pulse per electrical rotation signal is generated based on U-phase induced voltage.

FGC	FG
High	1 pulse/electrical rotation
Middle	3 pulses/electrical rotation
Low or Open	3 pulses/electrical rotation

Note: When FGC = Middle, the operation mode is switched to Test mode (square-wave drive)

16. Internal Protection by V_{CC}-Power Supply Monitoring

When turning the power on/off using a low-voltage power supply, all the drive outputs are set Low to prevent the power device from short-circuiting.

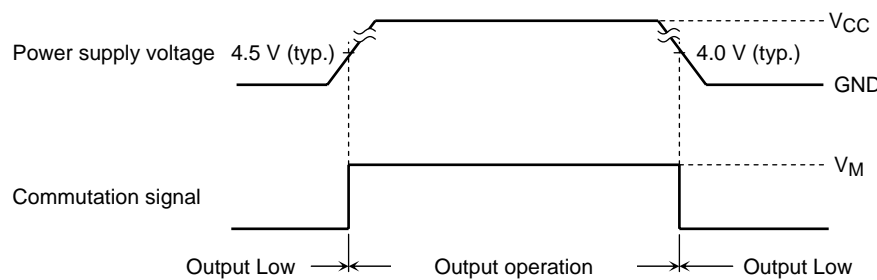

Internal protection by V_M-power supply monitoring

When the motor power supply V_M is high, all the drive outputs are set Low to prevent the power device from short-circuiting. Applying a 2.2-V input voltage to the VCOM pin sets the drive outputs (U_H, U_L, V_H, V_L, W_H and W_L) Low. When the VCOM input voltage falls below 1.85 V, the output operation is restarted.

- V_{COM} > 2.2 V (typ.) → Output Low (Stop)
- V_{COM} < 1.85 V (typ.) → Output operation (Restart)

17. Overcurrent Protection

Preliminary

Two input signals can be used for current limiting.

(1) Iduty

The voltage specified by the Iduty pin and the voltage converted from a phase current is compared. When the former voltage is lower than the latter one, the duty cycle for the drive outputs is limited by limiting the modulated waveform. During an actual operation, the full-wave rectification of the three-phase current is performed with reference to the internal reference voltage of 2.5 V. Then, this full-wave-rectified waveform and the voltage specified by the Iduty are compared. Therefore, applying an input voltage of 2.5 V or lower to the Iduty pin limits the current so that the motor is not rotated. The Iduty input voltage range is from 2.5 V to 4.0 V. When the Iduty input is not used for the protection feature, the Iduty voltage must be set to Vrefout.

Example) imiting the IOUT current to 1 A when the shunt resistor value R1 is 0.33 Ω.

$$V_P = I_{OUT} (A) \times R_1 (\Omega) \times G + 2.5 (V)$$

G: 3 (Value of the internal amplification)

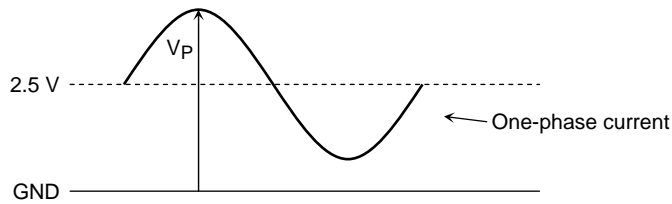

$$V_P = 1.0 \times 0.33 \times 3 + 2.5 V = 0.99 + 2.5 = 3.49 V$$

Thus, setting the Iduty pin voltage to 3.49 V limits the phase current peak to about 1 A. The setting error can be considered to be ± 20%.

(Internal operation image)

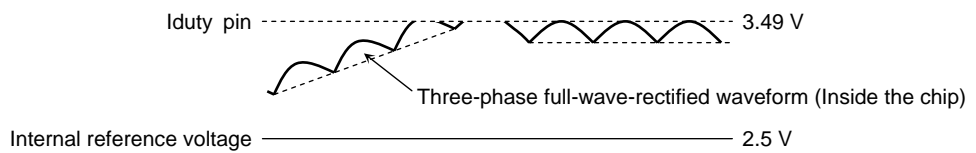

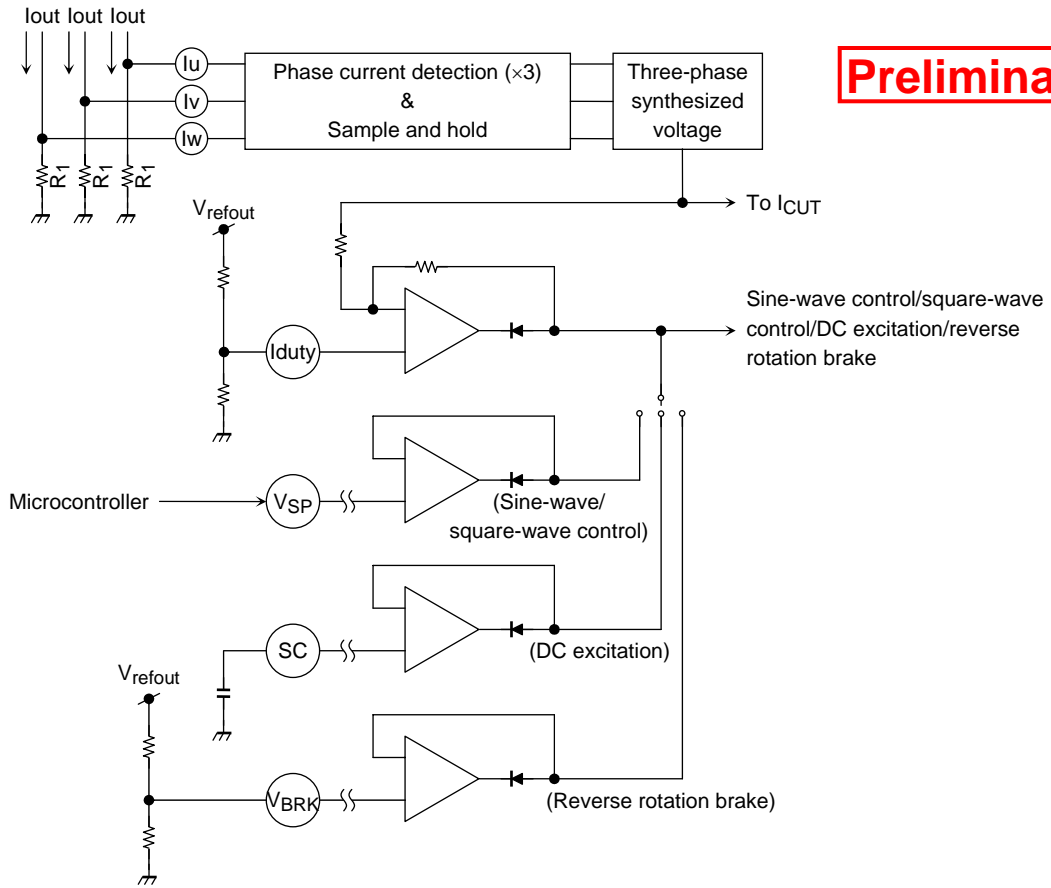

(2) **Icut**

When the three-phase synthesized voltage reaches the voltage specified by the Icut pin, drive outputs (UH, UL, VH, VL, WH and WL) are set Low. The drive output operation is restarted when a voltage is reapplied to the VSP pin. In such cases, the VSP voltage must be no higher than 1.5 V. The input voltage range for the Icut pin is 2.5 V to Vrefout. The Iduty and Icut voltages should be $I_{duty} \leq I_{cut}$.

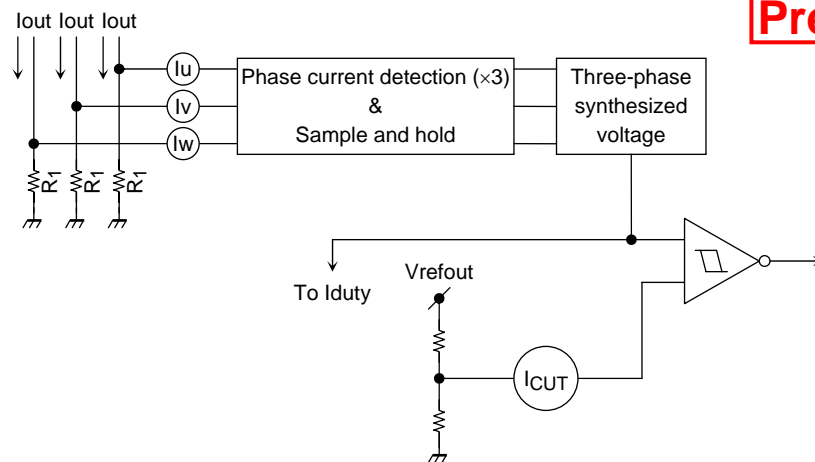

Example) Limiting the IOUT current to 1.5 A when the shunt resistor value R1 is 0.33 Ω.

$$V_P = I_{OUT} \text{ (A)} \times R_1 \text{ (}\Omega\text{)} \times G + 2.5 \text{ (V)}$$

G: 3 (Value of the internal amplification)

$$V_P = 1.5 \times 0.33 \times 3 + 2.5 \text{ V} = 1.485 + 2.5 = 3.99 \text{ V}$$

Thus, setting the Iduty pin voltage to 3.99 V limits the phase current peak to about 1.5 A. The setting error can be considered to be ± 20%.

These features are intended for the protection of external output drivers. Considerations on the internal delay between the overcurrent detection and the actual stop timing of the operation are required to avoid any damage to the external power device.

Preliminary

Timing Chart (CW/CCW = Low, REV = Low)

The operation image of the drive outputs corresponding to detected voltages Eu, Ev and Ew is illustrated below.

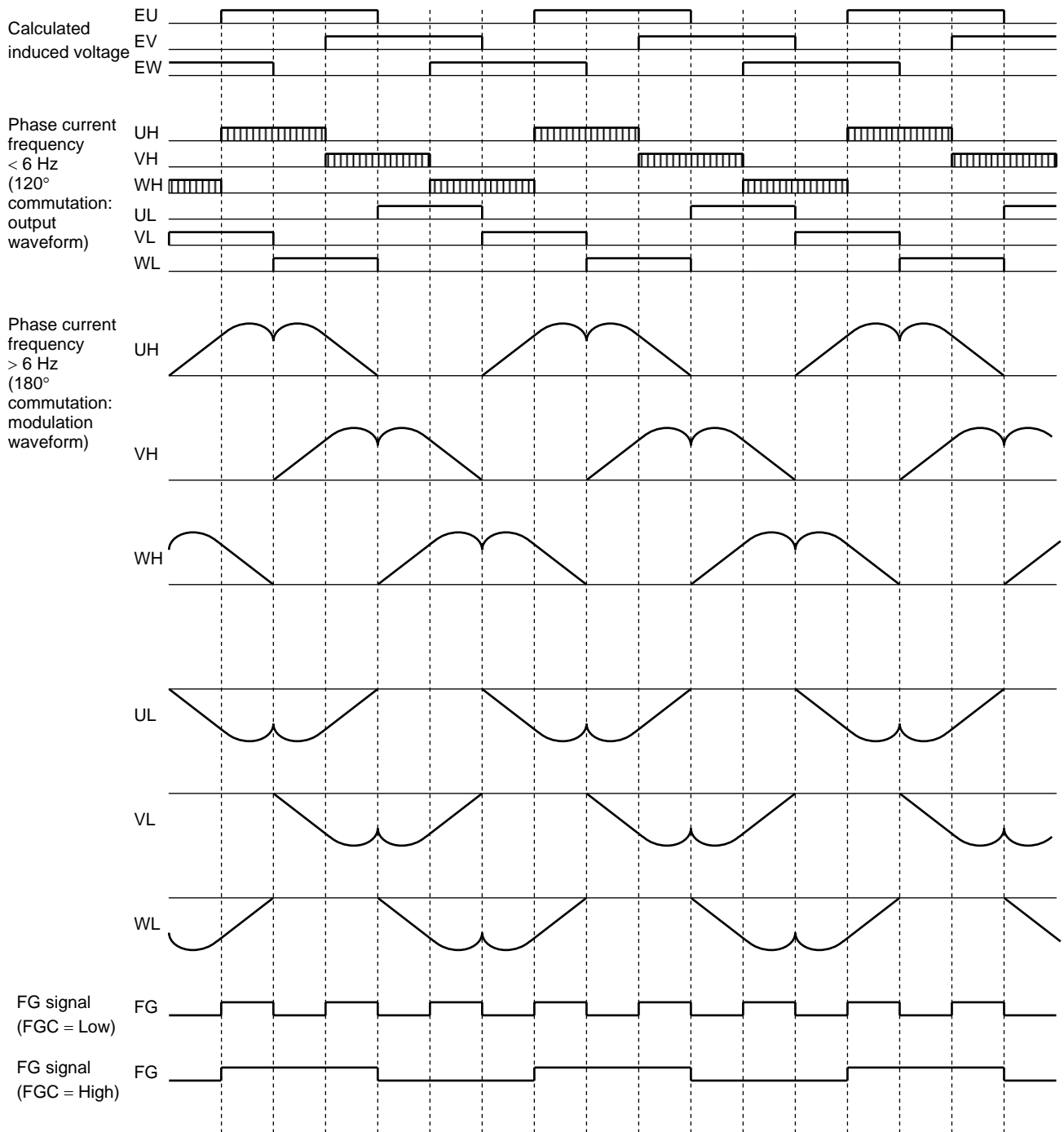

Timing Chart (CW/CCW = High, REV = Low)

Preliminary

The operation image of the drive outputs corresponding to detected voltages Eu, Ev and Ew is illustrated below.

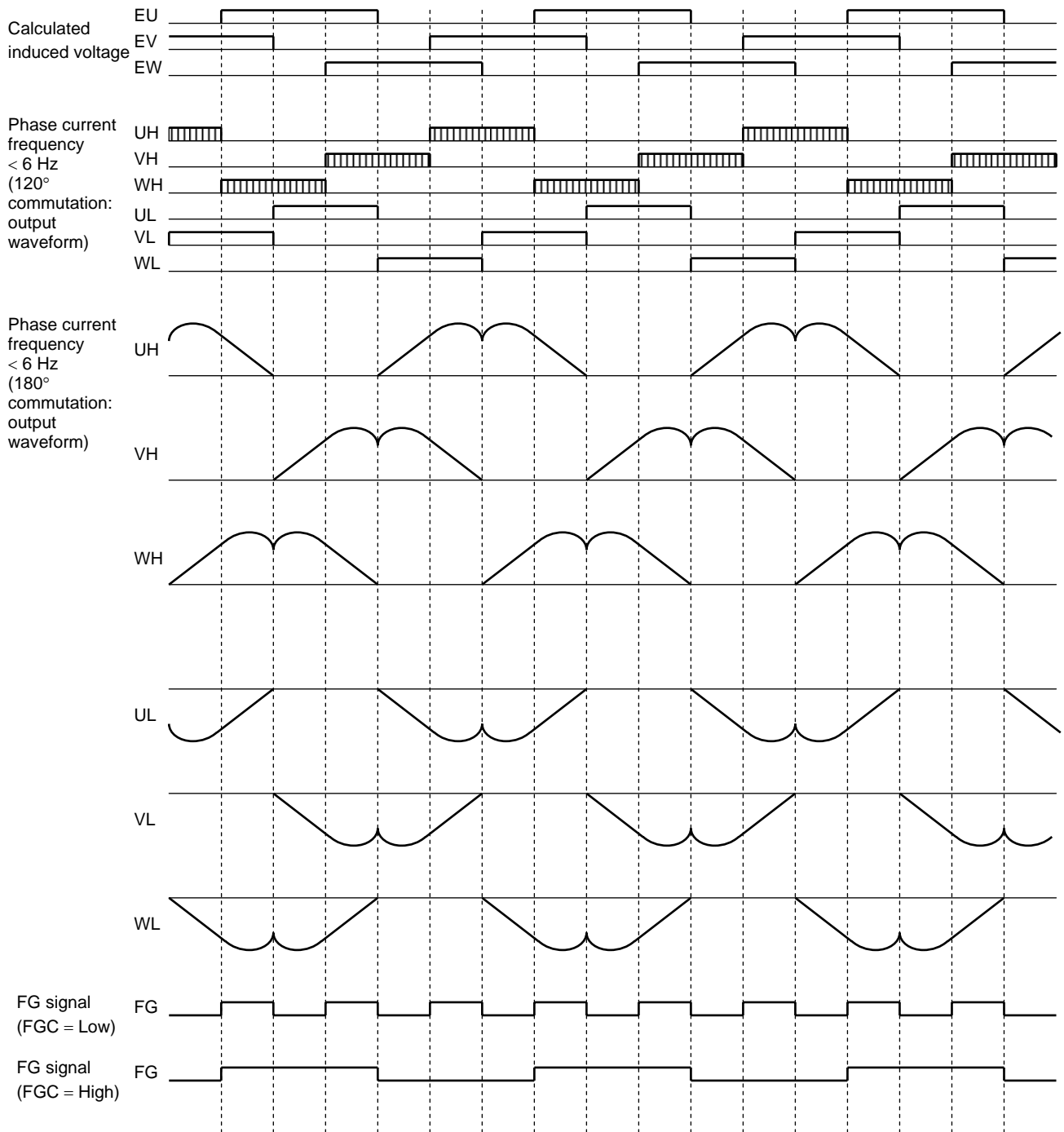

Notes on Contents

Preliminary

1. Block Diagrams

Some of the functional blocks, circuits, or constants in the block diagram may be omitted or simplified for explanatory purposes.

2. Equivalent Circuits

The equivalent circuit diagrams may be simplified or some parts of them may be omitted for explanatory purposes.

3. Timing Charts

Timing charts may be simplified for explanatory purposes.

4. Application Circuits

The application circuits shown in this document are provided for reference purposes only. Thorough evaluation is required, especially at the mass production design stage.

Toshiba does not grant any license to any industrial property rights by providing these examples of application circuits.

5. Test Circuits

Components in the test circuits are used only to obtain and confirm the device characteristics. These components and circuits are not guaranteed to prevent malfunction or failure from occurring in the application equipment.

IC Usage Considerations

Notes on handling of ICs

- (1) The absolute maximum ratings of a semiconductor device are a set of ratings that must not be exceeded, even for a moment. Do not exceed any of these ratings.
Exceeding the rating(s) may cause the device breakdown, damage or deterioration, and may result injury by explosion or combustion.
- (2) Use an appropriate power supply fuse to ensure that a large current does not continuously flow in case of over current and/or IC failure. The IC will fully break down when used under conditions that exceed its absolute maximum ratings, when the wiring is routed improperly or when an abnormal pulse noise occurs from the wiring or load, causing a large current to continuously flow and the breakdown can lead smoke or ignition. To minimize the effects of the flow of a large current in case of breakdown, appropriate settings, such as fuse capacity, fusing time and insertion circuit location, are required.
- (3) If your design includes an inductive load such as a motor coil, incorporate a protection circuit into the design to prevent device malfunction or breakdown caused by the current resulting from the inrush current at power ON or the negative current resulting from the back electromotive force at power OFF. IC breakdown may cause injury, smoke or ignition.
Use a stable power supply with ICs with built-in protection functions. If the power supply is unstable, the protection function may not operate, causing IC breakdown. IC breakdown may cause injury, smoke or ignition.
- (4) Do not insert devices in the wrong orientation or incorrectly.
Make sure that the positive and negative terminals of power supplies are connected properly. Otherwise, the current or power consumption may exceed the absolute maximum rating, and exceeding the rating(s) may cause the device breakdown, damage or deterioration, and may result injury by explosion or combustion.
In addition, do not use any device that is applied the current with inserting in the wrong orientation or incorrectly even just one time.

Points to remember on handling of ICs**Preliminary****(1) Over current Protection Circuit**

Over current protection circuits (referred to as current limiter circuits) do not necessarily protect ICs under all circumstances. If the Over current protection circuits operate against the over current, clear the over current status immediately.

Depending on the method of use and usage conditions, such as exceeding absolute maximum ratings can cause the over current protection circuit to not operate properly or IC breakdown before operation. In addition, depending on the method of use and usage conditions, if over current continues to flow for a long time after operation, the IC may generate heat resulting in breakdown.

(2) Heat Radiation Design

In using an IC with large current flow such as power amp, regulator or driver, please design the device so that heat is appropriately radiated, not to exceed the specified junction temperature (T_J) at any time and condition. These ICs generate heat even during normal use. An inadequate IC heat radiation design can lead to decrease in IC life, deterioration of IC characteristics or IC breakdown. In addition, please design the device taking into consideration the effect of IC heat radiation with peripheral components.

(3) Back-EMF

When a motor rotates in the reverse direction, stops or slows down abruptly, a current flow back to the motor's power supply due to the effect of back-EMF. If the current sink capability of the power supply is small, the device's motor power supply and output pins might be exposed to conditions beyond maximum ratings. To avoid this problem, take the effect of back-EMF into consideration in system design.

Package Dimensions

Preliminary

QFP52-P-1010-0.65

Unit : mm

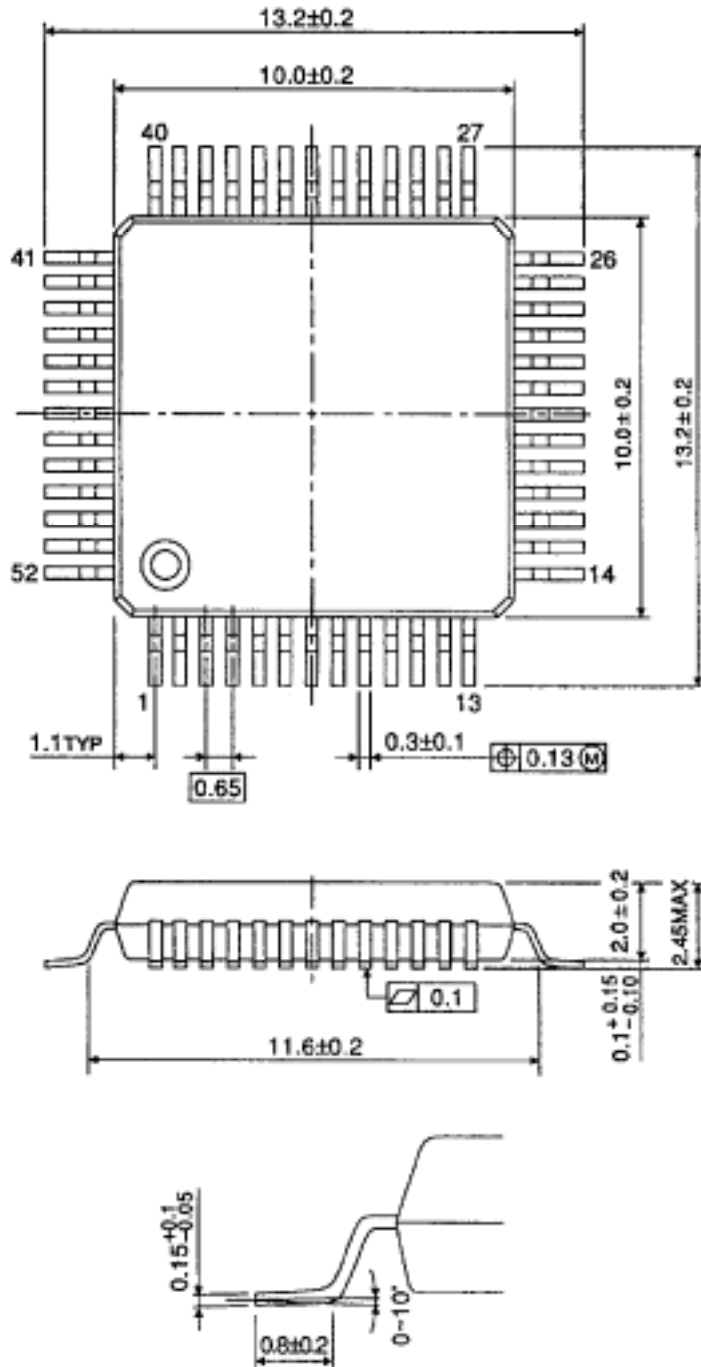

Weight: 0.45 g (typ.)

Preliminary**RESTRICTIONS ON PRODUCT USE**

070122EBA_R6

- The information contained herein is subject to change without notice. 021023_D
- TOSHIBA is continually working to improve the quality and reliability of its products. Nevertheless, semiconductor devices in general can malfunction or fail due to their inherent electrical sensitivity and vulnerability to physical stress. It is the responsibility of the buyer, when utilizing TOSHIBA products, to comply with the standards of safety in making a safe design for the entire system, and to avoid situations in which a malfunction or failure of such TOSHIBA products could cause loss of human life, bodily injury or damage to property.
In developing your designs, please ensure that TOSHIBA products are used within specified operating ranges as set forth in the most recent TOSHIBA products specifications. Also, please keep in mind the precautions and conditions set forth in the "Handling Guide for Semiconductor Devices," or "TOSHIBA Semiconductor Reliability Handbook" etc. 021023_A
- The TOSHIBA products listed in this document are intended for usage in general electronics applications (computer, personal equipment, office equipment, measuring equipment, industrial robotics, domestic appliances, etc.). These TOSHIBA products are neither intended nor warranted for usage in equipment that requires extraordinarily high quality and/or reliability or a malfunction or failure of which may cause loss of human life or bodily injury ("Unintended Usage"). Unintended Usage include atomic energy control instruments, airplane or spaceship instruments, transportation instruments, traffic signal instruments, combustion control instruments, medical instruments, all types of safety devices, etc. Unintended Usage of TOSHIBA products listed in this document shall be made at the customer's own risk. 021023_B
- The products described in this document shall not be used or embedded to any downstream products of which manufacture, use and/or sale are prohibited under any applicable laws and regulations. 060106_Q
- The information contained herein is presented only as a guide for the applications of our products. No responsibility is assumed by TOSHIBA for any infringements of patents or other rights of the third parties which may result from its use. No license is granted by implication or otherwise under any patents or other rights of TOSHIBA or the third parties. 070122_C
- Please use this product in compliance with all applicable laws and regulations that regulate the inclusion or use of controlled substances.
Toshiba assumes no liability for damage or losses occurring as a result of noncompliance with applicable laws and regulations. 060819_AF
- The products described in this document are subject to foreign exchange and foreign trade control laws. 060925_E